



SKU	24952
Capacidade	830 ml
Altura	168,10 mm
Diâmetro	90,4 mm
Peso	375 gramas
Fechamento	Tampa 74 mm

Qtde. caixa	15 unidades
Qtde. pallet	1050 unidades
Altura pallet	1,35 m
Peso pallet	493 kg
Medida pallet	1,00 x 1,20 m
Cores	Branco



BIDOLUX

Garrafas e Potes de Vidro / Conservas

POTE AZ 500

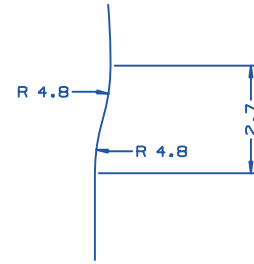
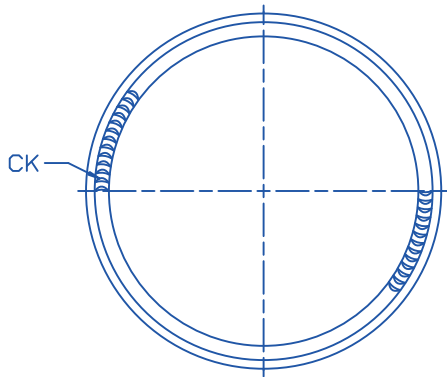

DETALHE 'A'
ESCALA 10:1

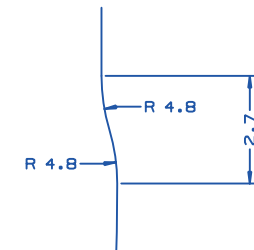

DETALHE 'B'
ESCALA 10:1

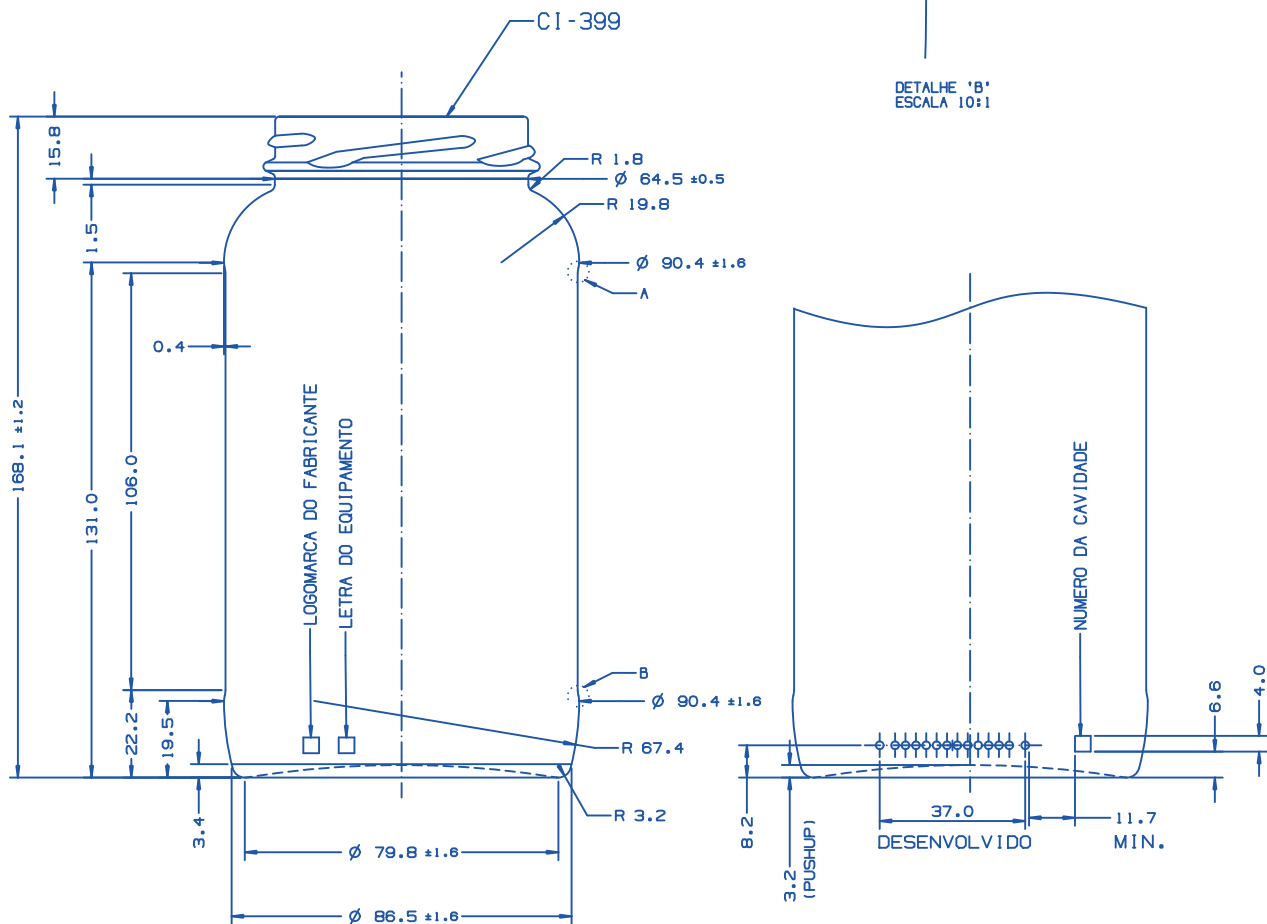

CARACTERISTICAS FISICO-DIMENSIONAIS

CARGA VERTICAL : 340 kgf/emb/min	CHOQUE TERMICO : $\Delta t \leq 50^\circ C$
VERTICALIDADE A 380° : MAX. 4.8 mm	IMPACTO : 51 cm/s
GRAU DE REDOZIMENTO : MAX. 4	OVALIZACAO CORPO : MAX. 2.4 mm
	CORDA ARRIBADA : MAX. 0.8 mm
	CORDA ABALLADA : MAX. 0.3 mm
ESPESSURA MINIMA	
PAREDE : 1.1 mm	TRATAMENTO A QUENTE
FUNDO : 2.5 mm	ARRIMATE - MEDIA : MAX. 15 CTU
RAZAO DE DISTRIBUICAO : 2,5 : 1	CORPO - MEDIA : 20 A 80 CTU
	TRATAMENTO A FRIO
	ANG. DE DESLIZAMENTO : MAX. 25°
TRANSMITANCIA	
AMBAR : 20 A 35 %	VERDE : 70 A 80 %
	BRANCA : >= 65 %