



SKU	9305
Capacidade	350 ml
Altura	128,50 mm
Diâmetro	68,7 mm
Peso	210 gramas
Fechamento	Tampa 63 mm

Qtde. caixa	15 unidades
Qtde. pallet	2313 unidades
Altura pallet	1,30 m
Peso pallet	470 kg
Medida pallet	1,00 x 1,20 m
Cores	Branco



BIDOLUX

Garrafas e Potes de Vidro / Conservas

POTE AZ 200 VD

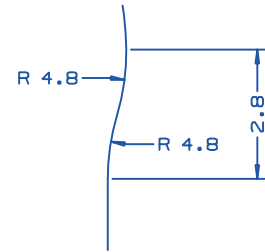
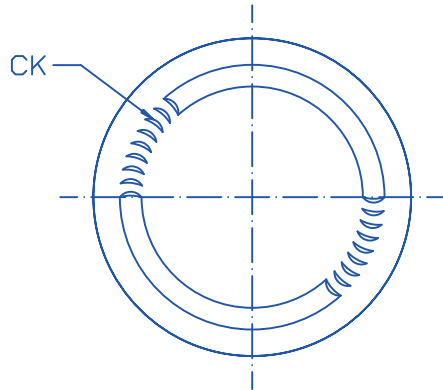

DETALHE 'A'
ESCALA 10:1

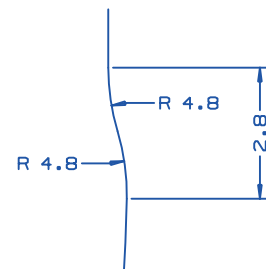

DETALHE 'B'
ESCALA 10:1

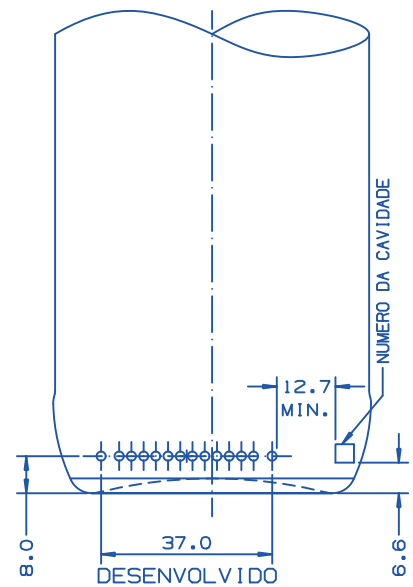
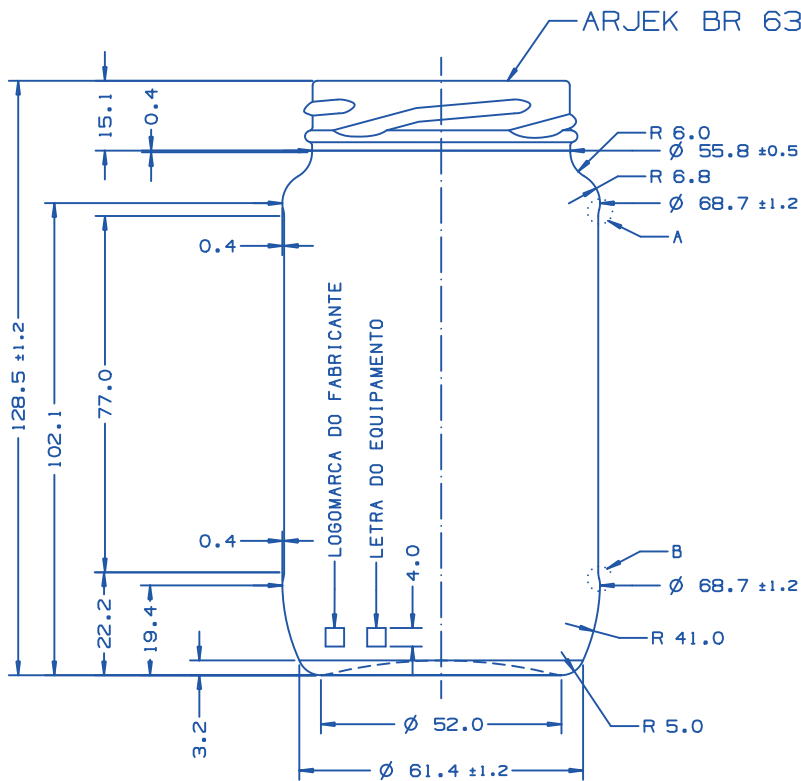

CARACTERISTICAS FISICO-DIMENSIONAIS

CARGA VERTICAL : 340 kgf/emb/min
 VERTICALIDADE A 360° : MAX. 4.0 mm
 GRAU DE RECOZIMENTO : MAX. 4

CHOQUE TERMICO : Δ t 42° C
 IMPACTO : 51 cm/s
 OVALIZACAO CORPO : MAX. 2.4 mm
 CORDA ARRADIADA : MAX. 0.8 mm
 CORDA ABALLADA : MAX. 0.4 mm

ESPESSURA MINIMA
 PAREDE RETA : 1.1 mm

TRATAMENTO A QUENTE

FUNDO : 2.0 mm
 RAZAO DE DISTRIBUICAO : 2.5 : 1

CORPO - MEDIA : 20 A 80 CTU
 TRATAMENTO A FRIO
 ANG. DE DESLIZAMENTO : MAX. 25°

AMBAR : 20 A 35 %

TRANSMITANCIA
 VERDE : 70 A 80 %

BRANCA : >= 85 %